



US009768241B2

(12) **United States Patent**  
**Lee et al.**

(10) **Patent No.:** **US 9,768,241 B2**  
(45) **Date of Patent:** **Sep. 19, 2017**

(54) **THIN FILM TRANSISTOR ARRAY  
SUBSTRATE AND ORGANIC  
LIGHT-EMITTING DIODE DISPLAY**

(52) **U.S. Cl.**  
CPC ..... **H01L 27/3265** (2013.01); **H01L 27/1255**  
(2013.01); **H01L 27/3262** (2013.01); **H01L**  
**27/3276** (2013.01); **H01L 51/50** (2013.01);  
**H01L 28/40** (2013.01)

(71) Applicant: **Samsung Display Co., Ltd**, Yongin-si,  
Gyeonggi-do (KR)

(58) **Field of Classification Search**  
CPC ..... H01L 27/3265; H01L 27/1255  
See application file for complete search history.

(72) Inventors: **Won-Se Lee**, Yongin (KR); **Won-Kyu  
Kwak**, Yongin (KR); **Se-Ho Kim**,  
Yongin (KR)

(56) **References Cited**

(73) Assignee: **Samsung Display Co., Ltd.**, Yongin-si  
(KR)

U.S. PATENT DOCUMENTS

(\* ) Notice: Subject to any disclaimer, the term of this  
patent is extended or adjusted under 35  
U.S.C. 154(b) by 0 days.

6,664,569 B2 12/2003 Moon  
7,858,974 B2 12/2010 Yoon et al.  
9,299,730 B2\* 3/2016 Lee ..... H01L 27/3262  
(Continued)

(21) Appl. No.: **15/064,526**

FOREIGN PATENT DOCUMENTS

(22) Filed: **Mar. 8, 2016**

KR 2001-0111328 12/2001  
KR 10-2008-0001106 A 1/2008  
(Continued)

(65) **Prior Publication Data**

US 2016/0260790 A1 Sep. 8, 2016

*Primary Examiner* — Mark Prenty

(74) *Attorney, Agent, or Firm* — Lewis Roca Rothgerber  
Christie LLP

**Related U.S. Application Data**

(63) Continuation of application No. 13/801,937, filed on  
Mar. 13, 2013, now Pat. No. 9,299,730.

**ABSTRACT**

(57) A thin film transistor (TFT) array substrate includes: a  
substrate; a first insulation layer on the substrate; a capacitor  
including a lower electrode on the first insulation layer, and  
an upper electrode arranged to overlap with the whole lower  
electrode and having an opening, and the upper electrode is  
insulated from the lower electrode by a second insulation  
layer; an inter-layer insulation film covering the capacitor; a  
node contact hole in the inter-layer insulation film and the  
second insulation layer, and within the opening; and a  
connection node on the inter-layer insulation film and elec-  
trically coupling the lower electrode and at least one TFT to  
each other through the node contact hole.

(30) **Foreign Application Priority Data**

Sep. 19, 2012 (KR) ..... 10-2012-0104215

**16 Claims, 7 Drawing Sheets**

(51) **Int. Cl.**

**H01L 27/32** (2006.01)  
**H01L 27/12** (2006.01)  
**H01L 51/50** (2006.01)  
**H01L 49/02** (2006.01)

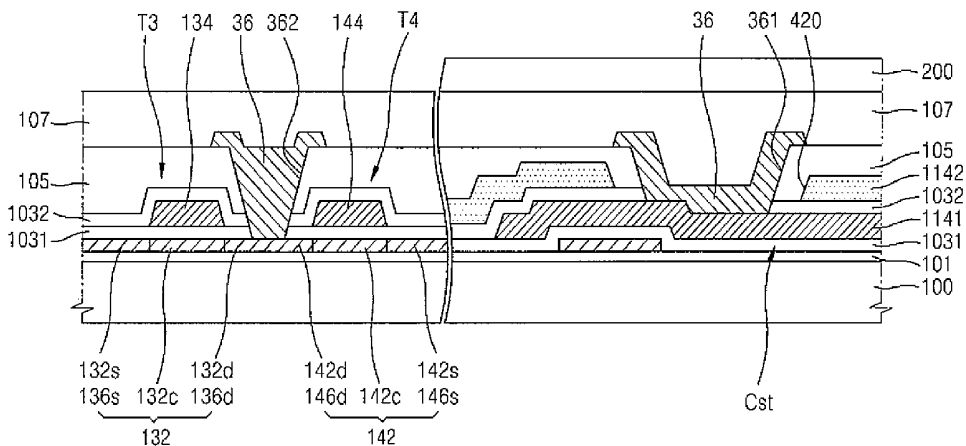

(56)

**References Cited**

U.S. PATENT DOCUMENTS

2008/0079005 A1 4/2008 Tseng  
2012/0146004 A1 6/2012 Lee et al.  
2013/0063330 A1 3/2013 Eom

FOREIGN PATENT DOCUMENTS

KR 10-2008-0050704 A 6/2008  
KR 10-2008-0085411 9/2008

\* cited by examiner



FIG. 2

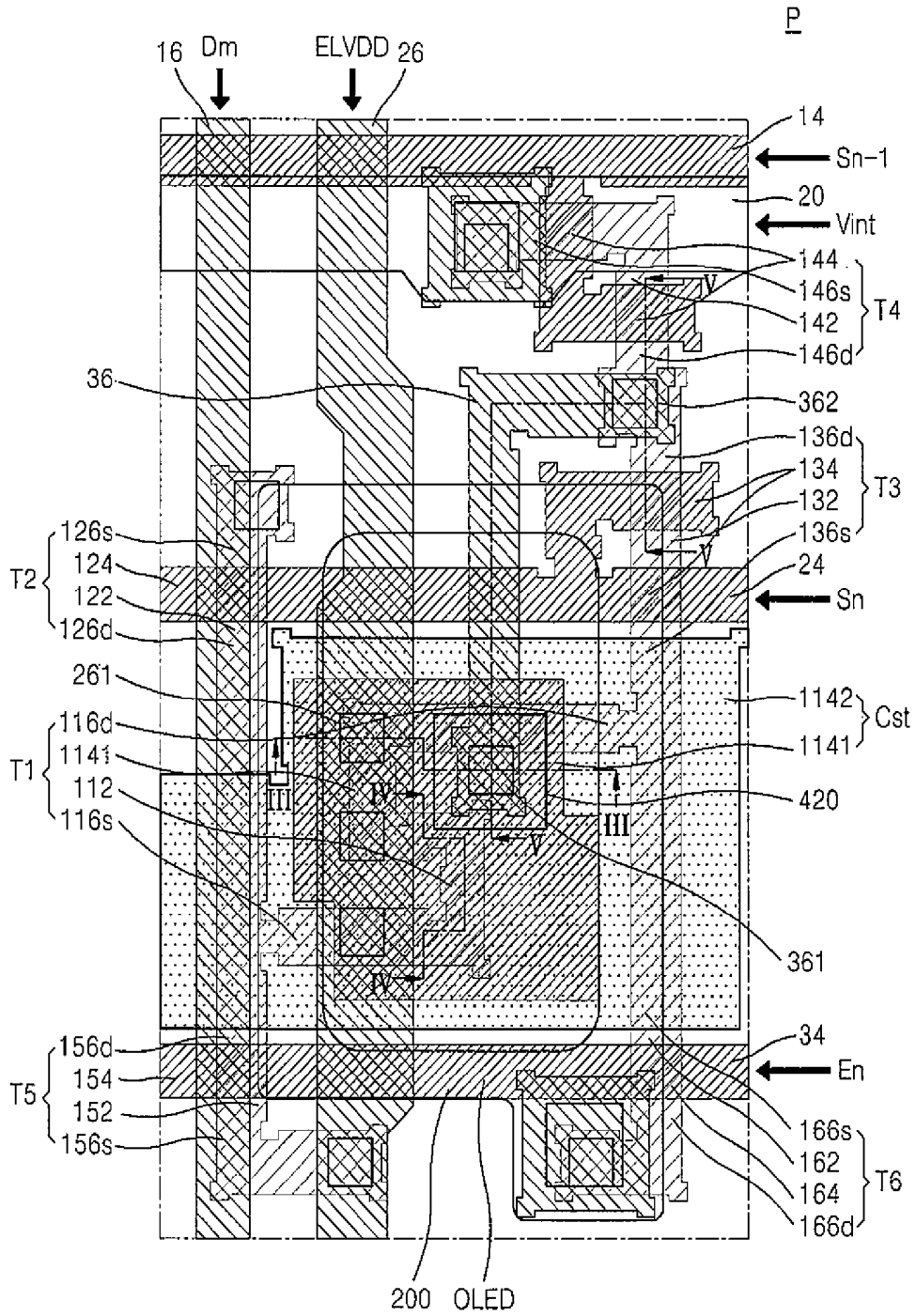

FIG. 3

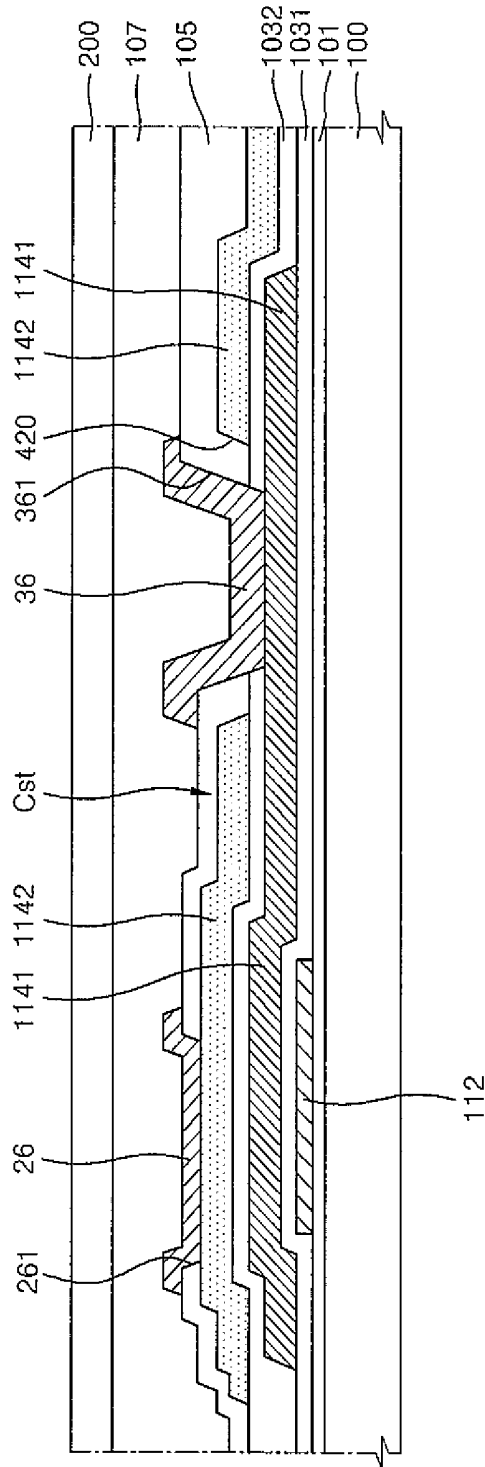

FIG. 4

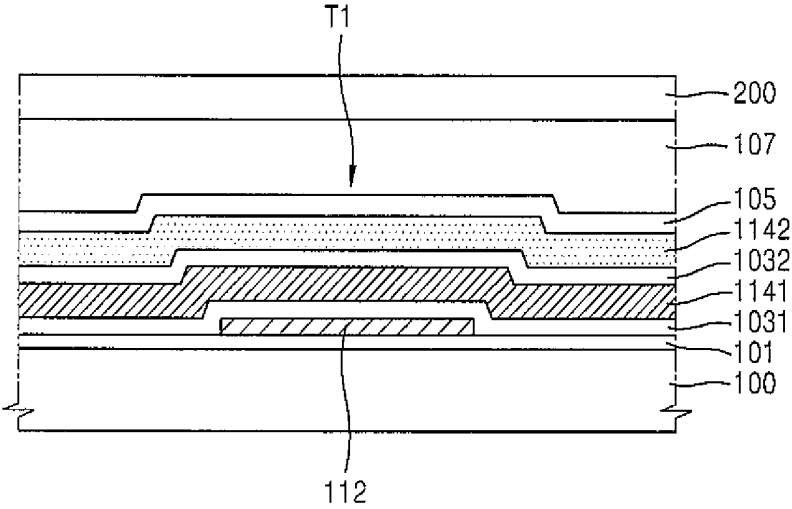
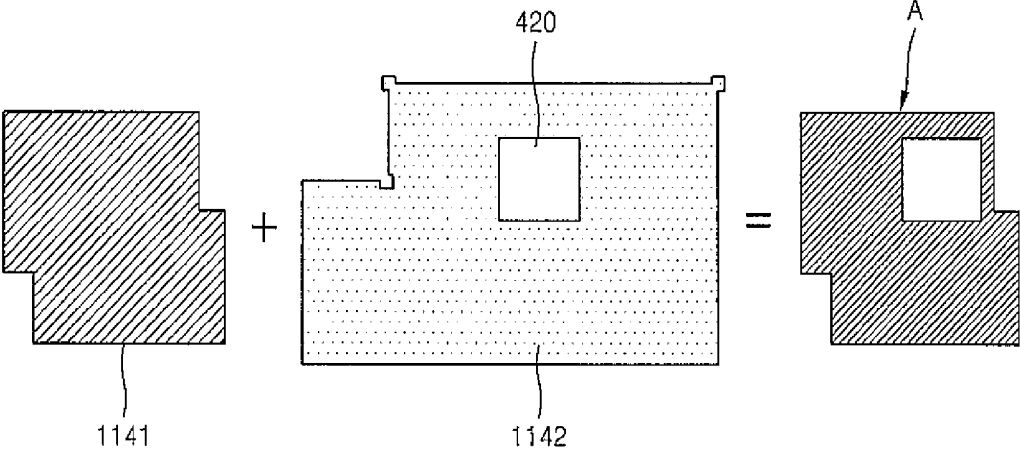



FIG. 6



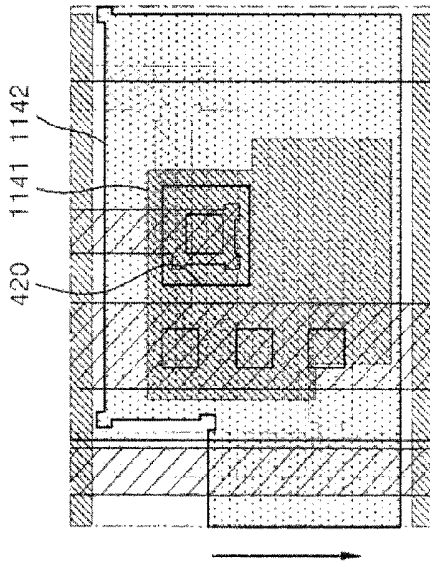

FIG. 7A

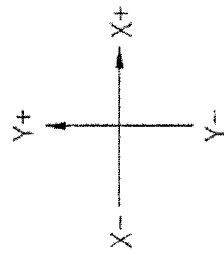

FIG. 7B

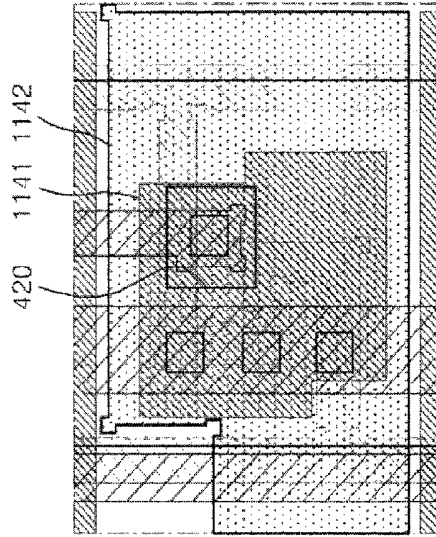

FIG. 7C

FIG. 7D

**THIN FILM TRANSISTOR ARRAY  
SUBSTRATE AND ORGANIC  
LIGHT-EMITTING DIODE DISPLAY**

CROSS-REFERENCE TO RELATED  
APPLICATION(S)

This application is a continuation of U.S. application Ser. No. 13/801,937, filed Mar. 13, 2013, which claims priority to and the benefit of Korean Patent Application No. 10-2012-0104215, filed on Sep. 19, 2012, in the Korean Intellectual Property Office, the disclosures of which are incorporated herein in their entirety by reference.

BACKGROUND

1. Field

Embodiments of the present invention relate to a thin film transistor (TFT) array substrate including at least one TFT and one storage capacitor, and an organic light-emitting diode (OLED) display.

2. Description of Related Art

An organic light-emitting diode (OLED) display may include two electrodes and an organic light-emitting layer interposed therebetween, wherein electrons injected from one electrode and holes injected from the other electrode are combined to form excitons that release energy, thereby emitting light.

Such an OLED display may also include a plurality of pixels, each pixel including an OLED, which is a self light-emitting device, a plurality of thin film transistors (TFTs), and a capacitor for driving the OLED.

The capacitor may include lower and upper electrodes and a dielectric interposed therebetween. Each electrode may be patterned through a photolithography process after a conductive layer is formed on the whole surface of a substrate. In a system in which a great number of large-sized panels are manufactured at the same time, a misalignment may occur between a substrate and a mask or a light exposure device within a tolerance (or tolerance level) of process equipment during a patterning process. Contrary to an intention of the design, an overlay deviation may occur between both of the electrodes of the capacitor due to the misalignment. Due to the overlay deviation, a capacitance may be generated that is different from a designed value, thereby resulting in low-gradation spots, abnormal colors, or the like.

SUMMARY

Aspects of embodiments of the present invention provide a thin film transistor (TFT) array substrate including a storage capacitor structure for maintaining a capacitance to be substantially constant even though an overlay deviation occurs, and an organic light-emitting diode (OLED) display employing the same.

According to an aspect of the present invention, a TFT array substrate includes: a substrate; a first insulation layer on the substrate; a capacitor including a lower electrode on the first insulation layer, and an upper electrode arranged to overlap with the whole lower electrode and having an opening, and the upper electrode is insulated from the lower electrode by a second insulation layer; an inter-layer insulation film covering the capacitor; a node contact hole in the inter-layer insulation film and the second insulation layer, and within the opening; and a connection node on the

inter-layer insulation film and electrically coupling the lower electrode and at least one TFT to each other through the node contact hole.

The opening may overlap with the lower electrode.

The upper electrode may be configured to receive a driving voltage through a driving voltage line formed from the same layer as the connection node.

The driving voltage line may be coupled to the upper electrode through another contact hole in the inter-layer insulation film.

The TFT array substrate may further include a driving TFT arranged to overlap with the capacitor. A driving gate electrode of the driving TFT may include the lower electrode.

The at least one TFT may include a compensation TFT coupled to the driving TFT and electrically coupled to the lower electrode through the connection node, and the compensation TFT may be configured to compensate for a threshold voltage of the driving TFT.

A compensation gate electrode of the compensation TFT may be formed from the same layer as the lower electrode.

The at least one TFT may include an initialization TFT electrically coupled to the lower electrode through the connection node, and the initialization TFT may be configured to provide an initialization voltage to the driving gate electrode of the driving TFT by being turned on in response to a previous scan signal.

An initialization gate electrode of the initialization TFT may be formed from the same layer as the lower electrode.

According to another aspect of the present invention, an OLED display includes: a substrate; a first insulation layer on the substrate; a scan line on the first insulation layer and configured to deliver a scan signal; a data line and a driving voltage line crossing the scan line, the data line and the driving voltage line being insulated by a second insulation layer and an inter-layer insulation film and configured to respectively deliver a data signal and a driving voltage; a pixel circuit coupled to the scan line and the data line and including at least one thin film transistor (TFT) and a capacitor; an OLED for emitting light by receiving the driving voltage from the pixel circuit, and the capacitor includes a lower electrode on the first insulation layer, and an upper electrode arranged to overlap with the whole lower electrode and having an opening, and the upper electrode is insulated from the lower electrode by the second insulation layer; a node contact hole in the inter-layer insulation film and the second insulation layer, and within the opening; and a connection node on the inter-layer insulation film and electrically coupling the lower electrode and the at least one TFT to each other through the node contact hole.

The opening may overlap with the lower electrode.

The upper electrode may be configured to receive a driving voltage through a driving voltage line formed from the same layer as the connection node.

The driving voltage line may be coupled to the upper electrode through another contact hole in the inter-layer insulation film.

The OLED display may further include a driving TFT arranged to overlap with the capacitor. A driving gate electrode of the driving TFT may include the lower electrode.

The at least one TFT may include a compensation TFT coupled to the driving TFT and electrically coupled to the lower electrode through the connection node, and the compensation TFT may be configured to compensate for a threshold voltage of the driving TFT.

A compensation gate electrode of the compensation TFT may be formed from the same layer as the lower electrode.

The at least one TFT may include an initialization TFT electrically coupled to the lower electrode through the connection node, and the initialization TFT may be configured to provide an initialization voltage to the driving gate electrode of the driving TFT by being turned on in response to a previous scan signal.

An initialization gate electrode of the initialization TFT may be formed from the same layer as the lower electrode.

The OLED display may further include a switching TFT for delivering the data signal to the driving TFT by being turned on by the scan signal.

### BRIEF DESCRIPTION OF THE DRAWINGS

The above and other features and aspects of the present invention will become more apparent by describing in detail exemplary embodiments thereof with reference to the attached drawings in which:

FIG. 1 is an equivalent circuit diagram of one pixel in an organic light-emitting diode (OLED) display according to an embodiment of the present invention;

FIG. 2 is a top view of the pixel in the OLED display of FIG. 1;

FIG. 3 is a cross-sectional view through line III-III of FIG. 2;

FIG. 4 is a cross-sectional view through line IV-IV of FIG. 2;

FIG. 5 is a cross-sectional view through line V-V of FIG. 2;

FIG. 6 is a top view schematically showing an overlapping region of a storage capacitor in the pixel of FIG. 2; and

FIGS. 7A to 7D are top views showing cases where an overlay deviation occurs between both electrodes of the storage capacitor in the pixel of FIG. 2.

### DETAILED DESCRIPTION

Embodiments of the present invention will be described in detail with reference to the attached drawings, so that one of ordinary skill in the art may implement the spirit and scope of the present invention. The present invention can be implemented in various different forms and is not limited to the embodiments described below.

Parts irrelevant to the description may have been omitted to more clearly describe the present invention, and like reference numerals denote like elements throughout the specification.

In addition, since the sizes and thicknesses of components in the drawings are arbitrarily shown for convenience of description, the present invention is not necessarily limited to the shown sizes and thicknesses.

In the drawings, the thicknesses of layers and regions are magnified for clarity. In addition, the thicknesses of some layers and regions are exaggerated for convenience of description. When it is described that a certain component, such as a layer, a film, a region, or a plate, is "above" or "on" another component, the certain component may be directly above another component, or a third component may be interposed therebetween.

In the specification, when a certain part "includes" a certain component, this indicates that the part may further include another component instead of excluding another component unless there is no different disclosure. In addition, the term "on" indicates that a certain part is located above or below another part and does not necessarily

indicate that the certain part is located above another part based on a direction of gravity.

As used herein, expressions such as "at least one of," when preceding a list of elements, modify the entire list of elements and do not modify the individual elements of the list.

An organic light-emitting diode (OLED) display according to an embodiment will now be described in detail with reference to FIGS. 1 to 5.

FIG. 1 is an equivalent circuit diagram of one pixel in an OLED display according to an embodiment of the present invention.

As shown in FIG. 1, the pixel in the OLED display includes a plurality of lines (or signal lines) 14, 24, 34, 16, 26, and 20 and a pixel circuit, which includes a plurality of thin film transistors (TFTs) T1, T2, T3, T4, T5, and T6 that are coupled to the plurality of signal lines 14, 24, 34, 16, 26, and 20 and a storage capacitor Cst. In addition, the pixel further includes an OLED for emitting light by receiving a driving voltage from the pixel circuit.

The plurality of TFTs T1, T2, T3, T4, T5, and T6 includes a driving TFT T1, a switching TFT T2, a compensation TFT T3, an initialization TFT T4, an operation control TFT T5, and a light-emitting control TFT T6.

The plurality of lines 14, 24, 34, 16, 26, and 20 includes a scan line 24 for delivering a scan signal Sn, a previous scan line 14 for delivering a previous scan signal Sn-1, a light-emitting control line 34 for delivering a light-emitting control signal En to the operation control TFT T5 and the light-emitting control TFT T6, a data line 16, which crosses the scan line 24 and delivers a data signal Dm, a driving voltage line 26, which delivers a driving voltage ELVDD and is formed to be almost parallel to the data line 16, and an initialization voltage line 20 for delivering an initialization voltage Vint for initializing the driving TFT T1.

A gate electrode G1 of the driving TFT T1 is coupled to one electrode Cst1 of the storage capacitor Cst, a source electrode S1 thereof is coupled to the driving voltage line 26 via the operation control TFT T5, and a drain electrode D1 thereof is electrically coupled to an anode of the OLED via the light-emitting control TFT T6. In response to a switching operation of the switching TFT T2, the driving TFT T1 receives the data signal Dm and provides a driving current Id to the OLED.

A gate electrode G2 of the switching TFT T2 is coupled to the scan line 24, a source electrode S2 thereof is coupled to the data line 16, and a drain electrode D2 thereof is coupled to the source electrode S1 of the driving TFT T1 and is also coupled to the driving voltage line 26 via the operation control TFT T5. The switching TFT T2 performs a switching operation for delivering the data signal Dm received through the data line 16 to the source electrode S1 of the driving TFT T1 by being turned on in response to the scan signal Sn received through the scan line 24.

A gate electrode G3 of the compensation TFT T3 is coupled to the scan line 24, a source electrode S3 thereof is coupled to the drain electrode D1 of the driving TFT T1 and is also coupled to the anode of the OLED via the light-emitting control TFT T6, and a drain electrode D3 thereof is coupled to the one electrode Cst1 of the storage capacitor Cst, a drain electrode D4 of the initialization TFT T4, and the gate electrode G1 of the driving TFT T1. The compensation TFT T3 couples the gate electrode G1 and the drain electrode D1 of the driving TFT T1 to each other by being turned on in response to the scan signal Sn received through the scan line 24 so that the driving TFT T1 is diode-coupled.

A gate electrode G4 of the initialization TFT T4 is coupled to the previous scan line 14, a source electrode S4 thereof is coupled to the initialization voltage line 20, and the drain electrode D4 thereof is coupled to the one electrode Cst1 of the storage capacitor Cst, the drain electrode D3 of the compensation TFT T3, and the gate electrode G1 of the driving TFT T1. The initialization TFT T4 delivers the initialization voltage Vint to the gate electrode G1 of the driving TFT T1 by being turned on in response to the previous scan signal Sn-1 received through the previous scan line 14 to perform an initialization operation for initializing a voltage of the gate electrode G1 of the driving TFT T1.

A gate electrode G5 of the operation control TFT T5 is coupled to the light-emitting control line 34, a source electrode S5 thereof is coupled to the driving voltage line 26, and a drain electrode D5 thereof is coupled to the source electrode S1 of the driving TFT T1 and the drain electrode D2 of the switching TFT T2.

A gate electrode G6 of the light-emitting control TFT T6 is coupled to light-emitting control line 34, a source electrode S6 thereof is coupled to the drain electrode D1 of the driving TFT T1 and the source electrode S3 of the compensation TFT T3, and a drain electrode D6 thereof is electrically coupled to the anode of the OLED. The operation control TFT T5 and the light-emitting control TFT T6 are concurrently (e.g., simultaneously) turned on in response to the light-emitting control signal En received through the light-emitting control line 34 to deliver the driving voltage ELVDD to the OLED so that the driving current Id flows through the OLED.

The other electrode Cst 2 of the storage capacitor Cst is coupled to the driving voltage line 26. The one electrode Cst1 of the storage capacitor Cst is coupled to the gate electrode G1 of the driving TFT T1, the drain electrode D3 of the compensation TFT T3, and the drain electrode D4 of the initialization TFT T4 via a connection node.

A cathode of the OLED is coupled to a common voltage ELVSS. Accordingly, the OLED emits light by receiving the driving current Id from the driving TFT T1 so that an image is displayed.

An operation of the pixel in the OLED display of FIG. 1 will now be described in detail.

During an initialization period, the previous scan signal Sn-1 at a low level is provided through the previous scan line 14. In response to the previous scan signal Sn-1 at a low level, the initialization TFT T4 is turned on, thereby providing the initialization voltage Vint to the gate electrode G1 of the driving TFT T1 via the initialization TFT T4 through the initialization voltage line 20. The driving TFT T1 is initialized by the initialization voltage Vint.

During a data programming period, the scan signal Sn at a low level is supplied through the scan line 24. In response to the scan signal Sn, the switching TFT T2 and the compensation TFT T3 are turned on.

Due to the turn-on state of the compensation TFT T3, the driving TFT T1 is diode-coupled and biased in a forward direction.

In this case, a compensation voltage Dm+Vth (Vth has a negative value) obtained by subtracting a threshold voltage Vth of the driving TFT T1 from the data signal Dm input through the data line 16 is applied to the gate electrode G1 of the driving TFT T1.

Then, the driving voltage ELVDD and the compensation voltage Dm+Vth are applied to both of the electrodes of the storage capacitor Cst, thereby storing charges corresponding to a voltage difference between both of the electrodes of the

storage capacitor Cst in the storage capacitor Cst. During a light-emitting period, the light-emitting control signal En provided through the light-emitting control line 34 is changed from a high level to a low level, thereby turning on the operation control TFT T5 and the light-emitting control TFT T6.

Then, the driving current Id is generated due to a voltage difference between a voltage at the gate electrode G1 of the driving TFT T1 and the driving voltage ELVDD and is supplied to the OLED through the light-emitting control TFT T6. During the light-emitting period, a gate-source voltage Vgs of the driving TFT T1 is maintained as '(Dm+Vth)-ELVDD' by the storage capacitor Cst, and according to a current-voltage relationship of the driving TFT T1, the driving current Id is determined regardless of the threshold voltage Vth of the driving TFT T1.

A structure of the pixel in the OLED display of FIG. 1 will now be described in detail with reference to FIGS. 2 to 5, which are based on FIG. 1. FIG. 2 is a top view of a pixel P in the OLED display of FIG. 1. FIG. 3 is a cross-sectional view through the line III-III of FIG. 2. FIG. 4 is a cross-sectional view through the line IV-IV of FIG. 2. FIG. 5 is a cross-sectional view through the line V-V of FIG. 2.

As shown in FIGS. 2 to 5, according to an embodiment, the pixel P in the OLED display includes the scan line 24, the previous scan line 14, the light-emitting control line 34, and the initialization voltage line 20, which apply the scan signal Sn, the previous scan signal Sn-1, the light-emitting control signal En, and the initialization voltage Vint, respectively, along a row direction, and includes the data line 16 and the driving voltage line 26, which cross each of the scan line 24, the previous scan line 14, the light-emitting control line 34, and the initialization voltage line 20, and apply the data signal Dm and the driving voltage ELVDD, respectively.

In addition, the pixel P includes the driving TFT T1, the switching TFT T2, the compensation TFT T3, the initialization TFT T4, the operation control TFT T5, the light-emitting control TFT T6, the storage capacitor Cst, and the OLED.

The driving TFT T1, the switching TFT T2, the compensation TFT T3, the initialization TFT T4, the operation control TFT T5, and the light-emitting control TFT T6 are formed along semiconductor layers 112, 122, 132, 142, 152, and 162, which are formed bent in various shapes, respectively. Each of the semiconductor layers 112, 122, 132, 142, 152, and 162 is formed of polysilicon. Each of the semiconductor layers 112, 122, 132, 142, 152, and 162 includes a channel region not doped with impurities, and a source region and a drain region, doped with impurities, formed at both sides of the channel region. The impurities vary according to types of the TFTs and may include N-type impurities and/or P-type impurities.

The semiconductor layers 112, 122, 132, 142, 152, and 162 include a driving semiconductor layer 112 formed in the driving TFT T1, a switching semiconductor layer 122 formed in the switching TFT T2, a compensation semiconductor layer 132 formed in the compensation TFT T3, an initialization semiconductor layer 142 formed in the initialization TFT T4, an operation control semiconductor layer 152 formed in the operation control TFT T5, and a light-emitting control semiconductor layer 162 formed in the light-emitting control TFT T6.

The driving TFT T1 includes the driving semiconductor layer 112, a driving gate electrode 114a, a driving source electrode 116s, and a driving drain electrode 116d. The driving semiconductor layer 112 is bent. The driving source

electrode **116s** corresponds to a driving source region **116s** doped with impurities in the driving semiconductor layer **112**, and the driving drain electrode **116d** corresponds to a driving drain region **116d** doped with impurities in the driving semiconductor layer **112**. The storage capacitor Cst is formed on the driving TFT **T1** to overlap with the driving TFT **T1**.

The storage capacitor Cst includes lower and upper electrodes **1141** and **1142** with a second gate insulation film **1032** interposed therebetween. The driving gate electrode **1141** also functions as the lower electrode **1141**. That is, the driving gate electrode **1141** includes the lower electrode **1141**. The second gate insulation film **1032** is formed of a dielectric, and a storage capacitance is determined by charges accumulated in the storage capacitor Cst and a voltage between the lower and upper electrodes **1141** and **1142**.

According to an embodiment, the lower electrode **1141** is formed as a floating electrode having an island shape and is formed of the same material layers as the scan line **24**, the previous scan line **14**, the light-emitting control line **34**, a switching gate electrode **124**, a compensation gate electrode **134**, an initialization gate electrode **144**, an operation control gate electrode **154**, and a light-emitting control gate electrode **164**.

The upper electrode **1142** may be formed on the second gate insulation film **1032** as a floating electrode having an island shape. In one embodiment, the upper electrode **1142** is arranged to overlap with the whole lower electrode **1141** and has a storage opening **420**. The storage opening **420** may have a shape of a simple closed curve penetrating the upper electrode **1142**. According to one embodiment, the simple closed curve refers to a closed figure in which a start point and an end point are the same when the closed curve is traced from the start point of the traced curve to draw a polygon, a circle, or the like. The upper electrode **1142** having the storage opening **420** may have a doughnut shape.

According to an embodiment of the present invention, by using the storage capacitor Cst including the upper electrode **1142**, which overlaps with the whole lower electrode **1141** and has the storage opening **420** having a simple closed curve, even though an overlay deviation occurs between the lower electrode **1141** and the upper electrode **1142** during a method of manufacturing the OLED display, the capacitance of the storage capacitor Cst may be maintained (e.g., always be maintained) to be substantially constant. This feature will be described in detail below with reference to FIGS. **6** and **7**.

The switching TFT **T2** includes the switching semiconductor layer **122**, the switching gate electrode **124**, a switching source electrode **126s**, and a switching drain electrode **126d**. The switching source electrode **126s** protrudes from the data line **16**, and the switching drain electrode **126d** corresponds to a switching drain region **126d** doped with impurities in the switching semiconductor layer **122**.

The compensation TFT **T3** includes the compensation semiconductor layer **132**, the compensation gate electrode **134**, a compensation source electrode **136s**, and a compensation drain electrode **136d**, wherein the compensation source electrode **136s** corresponds to a compensation source region **136s** doped with impurities in the compensation semiconductor layer **132**, and the compensation drain electrode **136d** corresponds to a compensation drain region **136d** doped with impurities in the compensation semiconductor layer **132**. The compensation drain electrode **136d** may be coupled to the lower electrode **1141** via a connection node

**36**. In one embodiment, the compensation gate electrode **134** prevents a leakage current by forming a separate dual gate electrode.

The initialization TFT **T4** includes the initialization semiconductor layer **142**, the initialization gate electrode **144**, an initialization source electrode **146s**, and an initialization drain electrode **146d**. The initialization drain electrode **146d** corresponds to an initialization drain region **146d** doped with impurities in the initialization semiconductor layer **142**. The initialization drain electrode **146d** may be coupled to the lower electrode **1141** via the connection node **36**. The initialization source electrode **146s** may be coupled to the initialization voltage line **20** via a connection member.

The operation control TFT **T5** includes the operation control semiconductor layer **152**, the operation control gate electrode **154**, an operation control source electrode **156s**, and an operation control drain electrode **156d**. The operation control source electrode **156s** is a portion of the driving voltage line **26**, and the operation control drain electrode **156d** corresponds to an operation control drain region **156d** doped with impurities in the operation control semiconductor layer **152**.

The light-emitting control TFT **T6** includes the light-emitting control semiconductor layer **162**, the light-emitting control gate electrode **164**, a light-emitting control source electrode **166s**, and a light-emitting control drain electrode **166d**. The light-emitting control source electrode **166s** corresponds to a light-emitting control source region **166s** doped with impurities in the light-emitting control semiconductor layer **162**, and the light-emitting control drain electrode **166d** may be coupled to a pixel electrode **200** via a connection member.

According to one embodiment, one end of the driving semiconductor layer **112** of the driving TFT **T1** is coupled to the switching semiconductor layer **122** and the operation control semiconductor layer **152**, and the other end thereof is coupled to the compensation semiconductor layer **132** and the light-emitting control semiconductor layer **162**. Thus, the driving source electrode **116s** is coupled to the switching drain electrode **126d** and the operation control drain electrode **156d**, and the driving drain electrode **116d** is coupled to the compensation source electrode **136s** and the light-emitting control source electrode **166s**.

The lower electrode **1141** of the storage capacitor Cst may be coupled to the compensation TFT **T3** and the initialization TFT **T4** via the connection node **36**. The connection node **36** may be formed in the same layer as the data line **16**. One end of the connection node **36** may be coupled to the lower electrode **1141** via a first node contact hole **361** formed in the second gate insulation film **1032** and an inter-layer insulation film **105**. The first node contact hole **361** may be formed within the storage opening **420** of the upper electrode **1142**. The other end of the connection node **36** may be coupled to the compensation drain electrode **136d** and the initialization drain electrode **146d** via a second node contact hole **362** formed in a first gate insulation film **1031**, the second gate insulation film **1032**, and the inter-layer insulation film **105**.

The upper electrode **1142** of the storage capacitor Cst may be used as a switching device for selecting a pixel from which light is emitted. In one embodiment, the switching gate electrode **124** is coupled to the scan line **24**, the switching source electrode **126s** is coupled to the data line **16**, and the switching drain electrode **126d** is coupled to the driving TFT **T1** and the operation control TFT **T5**.

The light-emitting control drain electrode **166d** of the light-emitting control TFT **T6** is directly coupled to the pixel

electrode **200** of the OLED via a via hole (not shown) formed on a protection film **107**.

A structure of an OLED display according to an embodiment of the present invention will now be described in detail in a layered order with reference to FIGS. **3** to **5**. For convenience of description, FIGS. **3** to **5** show only layers from a substrate **100** to the pixel electrode **200**. In FIGS. **3** to **5**, a structure of the driving TFT **T1**, the compensation TFT **T3**, and the initialization TFT **T4** is mainly described. The storage capacitor **Cst** is described together with them. Since the other TFTs **T2**, **T5**, and **T6** substantially have a similar (or the same) structure as the driving TFT **T1**, the compensation TFT **T3**, and the initialization TFT **T4**, a detailed description thereof is omitted.

In one embodiment, a buffer layer **101** is formed on the substrate **100**, which may be an insulation substrate formed of glass, quartz, ceramic, plastic, or the like.

The driving semiconductor layer **112**, the compensation semiconductor layer **132**, and the initialization semiconductor layer **142** are formed on the buffer layer **101**. Although not shown, the driving semiconductor layer **112** may include a driving channel region, and a driving source region and a driving drain region facing each other with the driving channel region therebetween. The compensation semiconductor layer **132** also includes a compensation channel region **132c**, and the compensation source region **136s** and the compensation drain region **136d** facing each other with the compensation channel region **132c** therebetween. The initialization semiconductor layer **142** also includes an initialization channel region **142c**, and an initialization source region **146s** and the initialization drain region **146d** facing each other with the initialization channel region **142c** therebetween.

The first gate insulation film **1031** is formed on the driving semiconductor layer **112**, the compensation semiconductor layer **132**, and the initialization semiconductor layer **142**. The first gate insulation film **1031** may be formed of silicon nitride ( $\text{SiN}_x$ ), silicon oxide ( $\text{SiO}_2$ ), or the like.

A first gate conductive layer, parts of which form the driving gate electrode **1141** including the lower electrode **1141** of the storage capacitor **Cst**, the scan line **24** including the compensation gate electrode **134**, the previous scan line **14** including the initialization gate electrode **144**, and the light-emitting control line **34** including the operation control gate electrode **154** and the light-emitting control gate electrode **164**, is formed on the first gate insulation film **1031**.

In one embodiment, the driving gate electrode **1141** or the lower electrode **1141** are separated from the previous scan line **14**, the scan line **24**, and the light-emitting control line **34** and overlap with the driving channel region of the driving semiconductor layer **112**. The compensation gate electrode **134** is coupled to the scan line **24** and overlaps with the compensation channel region **132c** of the compensation semiconductor layer **132**. The initialization gate electrode **144** is coupled to the previous scan line **14** and overlaps with the initialization channel region **142c** of the initialization semiconductor layer **142**.

The second gate insulation film **1032** covers the first gate conductive layer and the first gate insulation film **1031**. The second gate insulation film **1032** may be formed of  $\text{SiN}_x$ ,  $\text{SiO}_2$ , or the like.

A second gate conductive layer **1142** including the upper electrode **1142** of the storage capacitor **Cst** is formed on the second gate insulation film **1032**. The upper electrode **1142**, which operates as a floating electrode, overlaps with the whole lower electrode **1141** to form the storage capacitor **Cst** and has the storage opening **420** overlapping with the lower

electrode **1141**. The storage opening **420** may have a shape of a simple closed curve penetrating the upper electrode **1142**.

The inter-layer insulation film **105** is formed on the second gate insulation film **1032** and the upper electrode **1142**. Like the first gate insulation film **1031** and the second gate insulation film **1032**, the inter-layer insulation film **105** is formed of a ceramic series material, such as  $\text{SiN}_x$ ,  $\text{SiO}_2$ , or the like.

The first node contact hole **361** is formed in the second gate insulation film **1032** and the inter-layer insulation film **105**, within the storage opening **420** of the upper electrode **1142** to expose the lower electrode **1141** to the outside. In addition, the second node contact hole **362** is formed in the first gate insulation film **1031**, the second gate insulation film **1032**, and the inter-layer insulation film **105** to expose the compensation drain region **136d** of the compensation semiconductor layer **132** and the initialization drain region **146d** of the initialization semiconductor layer **142**.

The driving voltage line **26**, the connection node **36**, and the data line **16** are formed on the inter-layer insulation film **105**. The driving voltage line **26** is coupled to the upper electrode **1142** of the storage capacitor **Cst** through a driving voltage line contact hole **261** so that the upper electrode **1142** receives the driving voltage ELVDD through the driving voltage line **26**. One end of the connection node **36** is coupled to the lower electrode **1141** of the storage capacitor **Cst** via the first node contact hole **361**, and the other end of the connection node **36** is coupled to the compensation drain electrode **136d** of the compensation TFT **T3** and the initialization drain electrode **146d** of the initialization TFT **T4** via the second node contact hole **362**. As described above, the compensation drain electrode **136d** and the initialization drain electrode **146d** correspond to the compensation drain region **136d** and the initialization drain region **146d**, respectively.

The protection film **107** covering the data line **16**, the driving voltage line **26**, and the connection node **36** is formed on the inter-layer insulation film **105**, and the pixel electrode **200** is formed on the protection film **107**.

Although not shown, the pixel electrode **200** may be coupled to the light-emitting control drain electrode **166d** through a via hole formed in the protection film **107**. A pixel-defining film (not shown) may be formed on the edge of the pixel electrode **200** and the protection film **107** and may have a pixel opening (not shown) to expose the pixel electrode **200**. The pixel-defining film may be formed of an organic material, such as a polyacrylate resin or polyimides, or a silica series inorganic material. An organic light-emitting layer (not shown) may be formed on the pixel electrode **200** exposed through the pixel opening, and a common electrode (not shown) may be formed on the organic light-emitting layer. As such, an OLED, including the pixel electrode **200**, the organic light-emitting layer, and the common electrode, may be formed.

In one embodiment, the pixel electrode **200** is an anode that is a hole injection electrode, and the common electrode is a cathode that is an electron injection electrode. However, the present invention is not necessarily limited thereto, and according to a driving method of the OLED display, the pixel electrode **200** may be cathode, and the common electrode may be an anode. Light is emitted when holes and electrons are injected from the pixel electrode **200** and the common electrode, respectively, and excitons generated by combining the injected holes and electrons to transition from an excited state to a ground state.

The organic light-emitting layer may be formed of a low-molecular weight organic material or a high-molecular weight organic material, such as Poly 3,4-ethylenedioxythiophene (PEDOT). In addition, the organic light-emitting layer may be formed of a multi-film structure including at least one of a hole injection layer (HIL), a hole transporting layer (HTL), an electron transporting layer (ETL), and an electron injection layer (EIL). In one embodiment, when the multi-film structure includes all of the HIL, the HTL, the ETL, and the EIL, the HIL is arranged on the pixel electrode **200** that is the anode, and then the HTL, the ETL, and the EIL are sequentially layered on the HIL. When the common electrode is formed of a reflection-type conductive material, the OLED display may be a rear-surface light-emitting type display. Examples of the reflection-type conductive material include lithium (Li), calcium (Ca), lithium fluoride/calcium (LiF/Ca), lithium fluoride/aluminum (LiF/Al), Al, silver (Ag), magnesium (Mg), and gold (Au).

FIG. 6 is a top view schematically showing an overlapping region of the storage capacitor Cst in the OLED display of FIG. 2. FIGS. 7A to 7D are top views showing cases where an overlay deviation occurs between the lower and upper electrodes **1141** and **1142** of the storage capacitor Cst in the OLED display of FIG. 2.

Referring to FIGS. 6 to 7D, the OLED display is characterized in that a capacitance of the storage capacitor Cst may be maintained (e.g., always maintained) to be substantially constant even though an overlay deviation occurs between the lower and upper electrodes **1141** and **1142** during a manufacturing process of the OLED display. The storage capacitor Cst includes the upper electrode **1142**, which overlaps with the whole lower electrode **1141** and has the storage opening **420** in a simple closed curve shape.

When the two or more layers overlapping each other are formed, if each of the two or more layers overlapping each other is shifted to the top, bottom, left, or right, an overlapping region due to the shift differs from an initially designed overlapping region, and this overlapping region difference is the overlay deviation. The overlay deviation may occur due to a misalignment between a substrate and a mask or a light exposure device when a conductive layer is formed on the whole substrate and is patterned by a photolithography process. This overlay deviation may have a high probability of occurring within a tolerance (or tolerance level) of process equipment in a system for concurrently (e.g., simultaneously) producing a great number of large panels.

Referring to FIG. 6, a capacitance between the lower and upper electrodes **1141** and **1142** of the storage capacitor Cst is determined by Equation 1. In Equation 1, C denotes a capacitance,  $\epsilon$  denotes a dielectric constant, A denotes an area of an overlapping region of the lower and upper electrodes **1141** and **1142**, and d denotes a distance between the lower and upper electrodes **1141** and **1142**.

$$C = \epsilon \frac{A}{d} \quad (1)$$

That is, the capacitance of the storage capacitor Cst may be determined by a dielectric constant  $\epsilon$  of the second gate insulation layer **1032**, the distance d between the lower and upper electrodes **1141** and **1142**, and the area A of the overlapping region of the lower and upper electrodes **1141** and **1142**. Thus, when the area A of the overlapping region of the lower and upper electrodes **1141** and **1142** varies, the capacitance also varies. In other words, when an overlay

deviation between the lower and upper electrodes **1141** and **1142** occurs, the capacitance may be different from a designed value. If the capacitance is different from the designed value, problems, such as low-gradation spots and abnormal colors, may occur, thereby degrading the quality of the OLED display.

To address these problems, an OLED display according to embodiments of the present invention is characterized in that the capacitance of the storage capacitor Cst may be maintained (e.g., always maintained) to be substantially constant even though an overlay deviation occurs between the lower and upper electrodes **1141** and **1142**. In one embodiment, the storage capacitor Cst includes the upper electrode **1142** having the storage opening **420** in a simple closed curve shape.

For example, FIG. 7A shows a case where the lower electrode **1141** is shifted to the top (in a +Y direction) rather than a designed location. FIG. 7B shows a case where the lower electrode **1141** is shifted to the bottom (in a -Y direction) rather than the designed location, FIG. 7C shows a case where the lower electrode **1141** is shifted to the right (in a +X direction) rather than the designed location, and FIG. 7D shows a case where the lower electrode **1141** is shifted to the left (in a -X direction) rather than the designed location.

A shift (or shift level) may be generated within a tolerance (or tolerance level) of process equipment, and the tolerance may be at most within a range in which the opening **420** of the upper electrode **1142** overlaps with the lower electrode **1141**. When a shift occurs to a region in which the opening **420** of the upper electrode **1142** does not overlap with the lower electrode **1141**, a problem may occur in forming the connection node **36** and the first node contact hole **361**, thereby making the pixel circuit inoperable. Thus, aspects of embodiments of the present invention do not deal with the case that the tolerance (or tolerance level) exceeds the range in which the opening **420** of the upper electrode **1142** overlaps with the lower electrode **1141**. So that the whole lower electrode **1141** and the upper electrode **1142** overlap each other, an area of the upper electrode **1142** may be equal to or greater than that of the lower electrode **1141**. For example, the area of the upper electrode **1142** may be as large as that of the lower electrode **1141** so that the capacitance may be maintained (e.g., always maintained) to be substantially constant even though a shift occurs.

According to each case of FIGS. 7A to 7D, even though the lower electrode **1141** is shifted to the top, bottom, left, and right from the designed location, the upper electrode **1142** overlaps (or always overlaps) with the whole lower electrode **1141**, and the opening **420** of the upper electrode **1142** overlaps (or always overlaps) with the lower electrode **1141**, and thus, the capacitance may be maintained to be substantially constant.

Although the lower electrode **1141** is shifted in FIGS. 7A to 7D, the present invention is not limited thereto, and the capacitance may be maintained to be substantially constant even though the upper electrode **1142** is shifted.

According to an embodiment of the present invention, the whole lower electrode and an upper electrode of a storage capacitor overlap each other, and an opening is formed in the upper electrode to overlap with the lower electrode, and thus even though an overlay deviation occurs between the two electrodes, a capacitance may be maintained (e.g., always maintained) to be substantially constant. Accordingly, low-gradation spots and abnormal colors due to a capacitance change may be prevented.

## 13

While the present invention has been particularly shown and described with reference to exemplary embodiments thereof, it will be understood by one of ordinary skill in the art that various changes in form and details may be made therein without departing from the spirit and scope of the present invention as defined by the following claims and their equivalents.

What is claimed is:

1. A thin film transistor (TFT) array substrate comprising:
  - a substrate;
  - a capacitor on the substrate, and comprising a lower electrode, an upper electrode arranged to overlap with the lower electrode, and an insulation layer interposed between the lower electrode and the upper electrode, the upper electrode having an opening which has a shape of a simple closed curve in a top view; and
  - a connection node on the upper electrode and electrically coupling at least one TFT, wherein an end portion of the connection node is coupled to the lower electrode through the opening.
2. The TFT array substrate of claim 1, wherein the simple closed curve is a polygon.
3. The TFT array substrate of claim 1, wherein the opening overlaps with the lower electrode.
4. The TFT array substrate of claim 1, further comprising a node contact hole within the opening, wherein the connection node is coupled to the lower electrode via the node contact hole.
5. The TFT array substrate of claim 4, wherein the size of the opening in the top view is greater than that of the node contact hole in the top view.
6. The TFT array substrate of claim 4, further comprising an inter-layer insulation film disposed between the upper electrode and the connection node, wherein the node contact hole is defined in the insulation layer and the inter-layer insulation film.
7. The TFT array substrate of claim 4, wherein a width of the opening is greater than that of the node contact hole.
8. The TFT array substrate of claim 1, further comprising a driving TFT arranged to overlap with the capacitor,

## 14

wherein the lower electrode overlaps a driving semiconductor layer of the driving TFT.

9. A organic light-emitting diode (OLED) display comprising:
  - a pixel circuit comprising at least one thin film transistor (TFT) and a capacitor; and
  - an OLED for emitting light by receiving the driving voltage from the pixel circuit, wherein the capacitor comprises a lower electrode, an upper electrode arranged to overlap with the lower electrode, and an insulation layer interposed between the lower electrode and the upper electrode, the upper electrode having an opening which has a shape of a simple closed curve in a top view, and
  - a connection node on the upper electrode, and electrically coupling the lower electrode and the at least one TFT to each other, an end portion of the connection node is coupled to the lower electrode through the opening.
10. The OLED display of claim 9, wherein the simple closed curve is a polygon.
11. The OLED display of claim 9, wherein the opening overlaps with the lower electrode.
12. The OLED display of claim 9, further comprising a driving TFT arranged to overlap with the capacitor, wherein the lower electrode overlaps a driving semiconductor layer of the driving TFT.
13. The OLED display of claim 9, further comprising a node contact hole within the opening, wherein the connection node is coupled to the lower electrode via the node contact hole.
14. The OLED display of claim 13, wherein a width of the opening is greater than that of the node contact hole.
15. The OLED display of claim 13, wherein the size of the opening in the top view is greater than that of the node contact hole in the top view.
16. The OLED display of claim 13, further comprising an inter-layer insulation film disposed between the upper electrode and the connection node, wherein the node contact hole is defined in the insulation layer and the inter-layer insulation film.

\* \* \* \* \*

